

## BLOWTEST CASE INSTRUCTION MANUAL

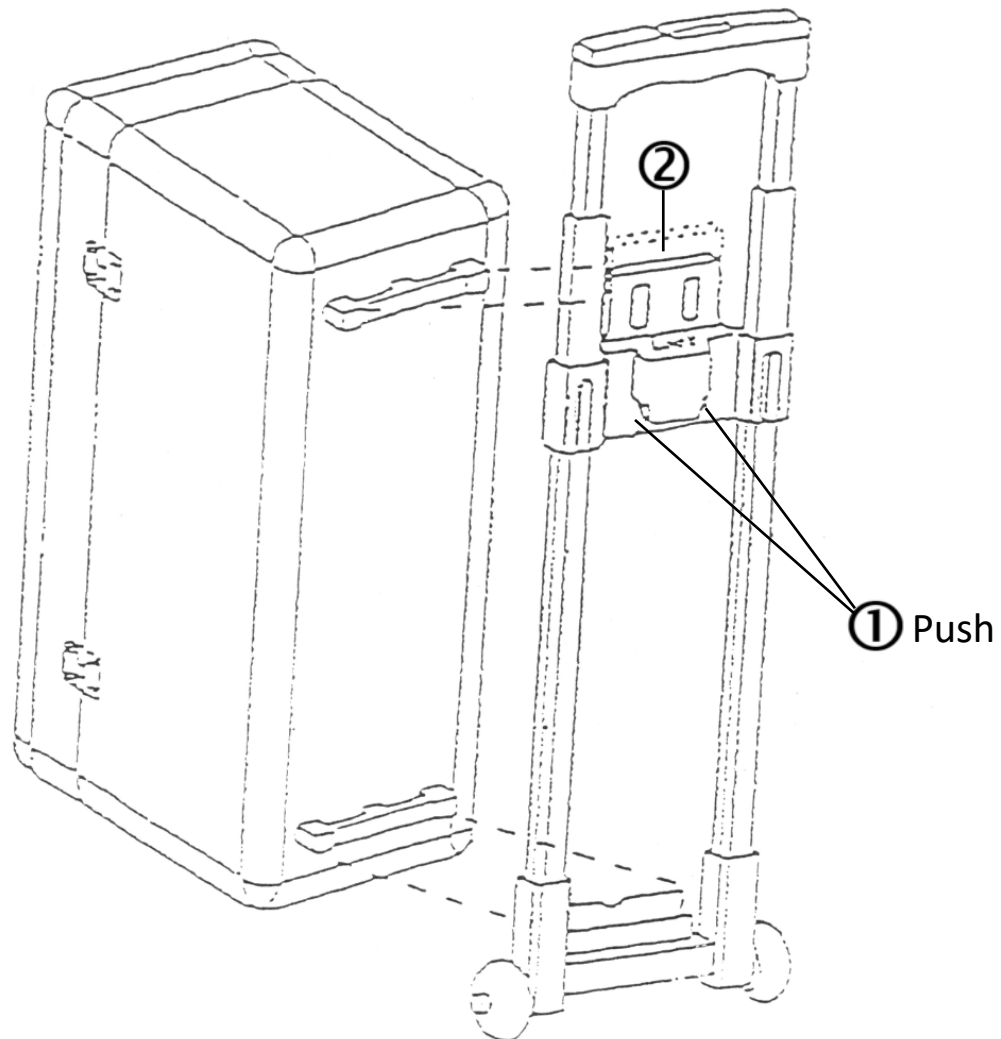

### TO ATTACH THE CASE TO LUGGAGE CART:

1. PRESS (1) & (2) PUSH, THE PUSH NUT TO BE OPENED
2. PLACE THE CASE IN THE CORRECTION POSITION.
3. PRESS (2) LOCK, TO ATTACH LUGGAGE CART FIRMLY TO THE CASE

### TO RELEASE THE CASE FROM LUGGAGE CART:

1. PRESS (1) & (2) PUSH, THE PUSCH NUT TO BE OPENED
2. OT REASE THE LUGGAGE CART FROM THE CASE FROM UP TO DOWN